

CAR1000~5000系列调压阀

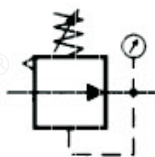

符号



订购码

CAR	2000	-	02
系列代号	壳体代号		螺纹接口
	1000		M5:M5
	2000		02:1/4"
	3000		03:3/8"
	4000		04:1/2"
	5000		06:3/4"
			10:1"

技术参数

型号	CAR1000-M5	CAR2000-02	CAR3000-02	CAR3000-03	CAR4000-04	CAR4000-06	CAR5000-06	CAR5000-10
接管口径	M5×0.8	1/4	1/4	3/8	1/2	3/4	3/4	1
压力表口径	1/16	1/8	1/8	1/8	1/4	1/4	1/4	1/4
额定流量	100	550	2500	2500	6000	6000	8000	8000
环境及流体温度	5~60℃							
保证耐压力	1.5Mpa{15.3kgf/cm ² }							
最高使用压力	1.0Mpa{10.2kgf/cm ² }							
调压范围	CAR1000: 0.05~0.7Mpa {0.51~7.1kgf/cm ² }							
	CAR2000~5000: 0.05~0.85Mpa {0.51~8.7kgf/cm ² }							
阀型	带溢流型							
重量	0.09	0.27	0.41	0.41	0.84	0.94	1.19	1.19

外形尺寸

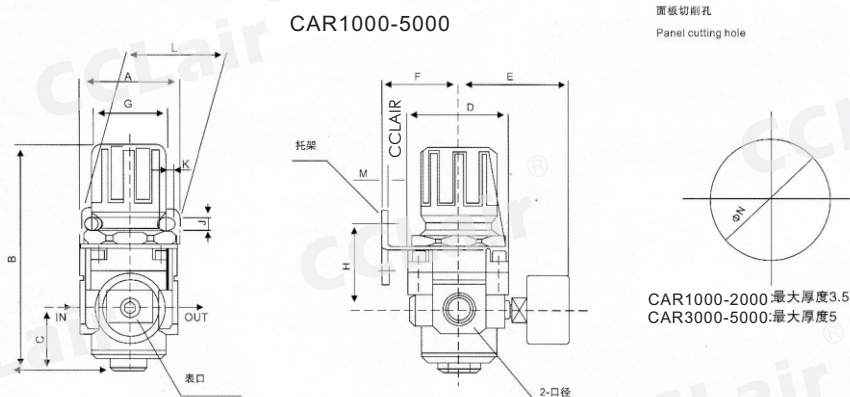

型号	口径	A	B	C	D	E	F	G	H	J	K	L	M	N
CAR1000	M5×0.8	30	61.5	11	25	26	25	28	30	4.5	6.5	40	2	20.5
CAR2000	1/4"	40	95	17	40	56.8	30	30	45	5.4	15.4	55	2.3	33.5
CAR3000	1/4", 3/8"	53	127.5	35	53	60.8	41	41	46	6.5	8.0	53	2.3	42.5
CAR4000	3/8", 1/2"	70	149.5	37.5	70	65.5	50	50	54	8.5	10.5	70	2.3	52.5
CAR4000-06	3/4"	75	154.5	40.5	70	69.5	50	50	56	8.5	10.5	70	2.3	52.5
CAR5000	3/4", 1	90	168	48	90	75.5	70	70	65.8	11	13	90	3.0	52.5